

3.2 RESIDENTIAL PROPANE SYSTEM INSTALLATION

ADVANCED FIELD TRAINING ACTIVITIES

TABLE OF CONTENTS

- I. General Instructions
- II. Task Information
- III. Advanced Field Training Activities
- IV. Railroad Commission Record & Employer Record

I. GENERAL INSTRUCTIONS

To the Company Representative or Operations Supervisor

The Advanced Field Training activities checklist must be completed within 30 calendar days of the date the employee attended a Railroad Commission Texas Propane Training class. Railroad Commission rules require these checklists to be retained in the employee's file and made available for inspection by an authorized representative of the Commission.

To the Skills Evaluator

Review Section II, Task Information, to ensure that the prerequisites and standards reflect your company's Standard Operating Procedures (SOP). You must witness and verify that the employee completed each task satisfactorily. Place a check mark in the box below each activity that the employee performs. Write "Not Applicable" or "N/A" on the form next to any listed activity that your company does not perform, per company policy or procedures.

To the Employee

This Advanced Field Training exercise is designed to document your ability to perform the LP-gas activities authorized by your Railroad Commission LP-gas certification. Make sure you know your company's Standard Operating Procedures (SOP) related to these activities, and take all necessary safety precautions while performing each activity.

II. TASK INFORMATION

- Course 3.2:** Installing Residential Propane Systems
- Standard:** Residential LP-gas systems must be installed in compliance with the applicable Railroad Commission LP-Gas Safety Rules, federal regulations and NFPA 54 and NFPA 58 standards as adopted by the Railroad Commission.
- Prerequisites:** Successful completion of Texas Propane Training course 3.2, "Installing Residential Propane Systems"
- References:** Applicable LP-gas codes, standards and company policies
- Method:** Tasks 1 through 14, inclusive

Check Method of Evaluation Used:

- Written and oral Performance on the job On-the-job training

III. ADVANCED FIELD TRAINING ACTIVITIES CHECKLIST

Task 1. Tank Sizing

Use Figure 1 and the tank vaporization formula to determine the minimum single aboveground ASME tank size and the minimum buried underground ASME tank size required to supply the gas appliances adequately under a given set of operating conditions.

The employee:

1. Correctly determined the total gas appliance demand.
2. Identified the most severe anticipated temperature and humidity operating conditions for the company's service location.
3. Used the "rule of thumb" vaporization capacity for ASME tanks and the prevailing air temperature multiplier to determine the required water capacity of an aboveground ASME tank to adequately supply the system with the tank at least 20 percent full.
4. Used the "rule of thumb" vaporization capacity for ASME tanks and the prevailing air temperature multiplier to determine the required water capacity of an underground ASME tank to adequately supply the system with the tank at least 20 percent full.

The employee is: qualified not qualified to perform Task 1.

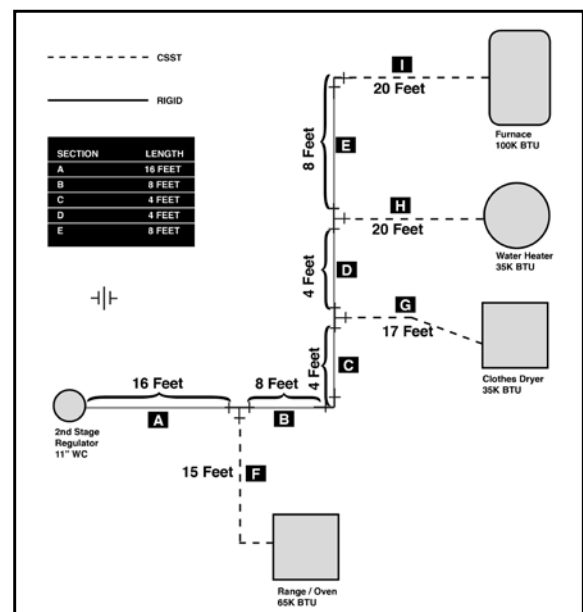
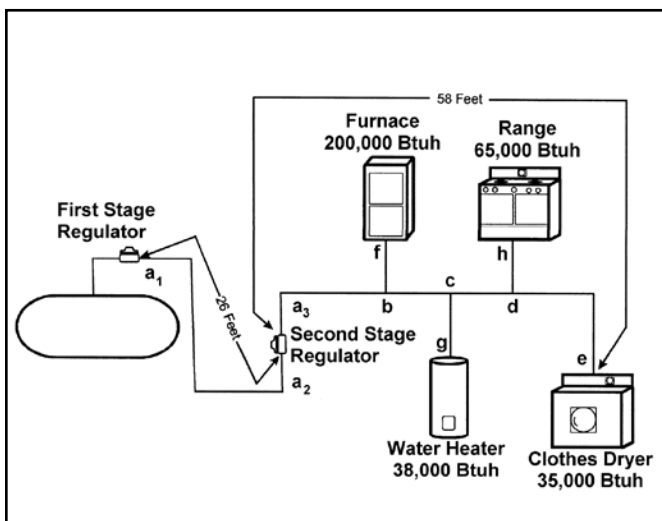

Task 2. Yard Line Sizing: PE Tubing

Use Figure 1 to determine the correct diameter of buried polyethylene (PE) tubing needed to supply the gas appliance distribution system.

The employee:

1. Correctly determined the total gas appliance demand.
2. Correctly determined the length of the PE tubing run.
3. Located and applied the information obtained for #1 and #2 above to the appropriate tube sizing table in NFPA 58.
4. Determined the correct PE tubing size to use for the installation.
5. Identified correct termination fittings for each end of the PE tubing.

The employee is: **qualified** **not qualified to perform Task 2.**

Task 3. Yard Line Sizing: Copper Tubing

Use Figure 1 to determine the correct diameter of buried copper tubing needed to supply the gas appliance distribution system.

The employee:

1. Correctly determined the total gas appliance demand.
2. Correctly determined the length of the copper tubing run.
3. Located and applied the information obtained for #1 and #2 above to the appropriate tube sizing table in NFPA 58.
4. Determined the correct copper tubing size to use for the installation.
5. Identified correct termination fittings for each end of the copper tubing.

The employee is: **qualified** **not qualified to perform Task 3.**

Task 4. Leak-Testing First-Stage Piping

Successfully test the first-stage piping for leaks, as required by NFPA 58.

The employee:

1. Installed a tee block or pressure gauge and tested the system according to NFPA requirements.
2. Documented the results of the leak test on the appropriate form

The employee is: **qualified** **not qualified to perform Task 4.**

Task 5. Sizing Interior Steel Piping

Use Figure 2 and the pipe sizing tables in NFPA 54 to size each section of an interior steel piping system.

1. Determine the total length from the outlet of the second-stage regulator to the most remote appliance on the system.
2. Using either the longest-length method or branch-length method, correctly size each section of piping on the system.

The employee is: **qualified** **not qualified to perform Task 5.**

Task 6. Pressure Test

Perform a pressure test on the interior steel piping system of a residential installation according to NFPA 54.

1. Select a gauge with the proper range.
2. Attach the gauge correctly to the piping.
3. Inspect the interior piping to ensure that all valves are closed and capped.
4. Pressure-test the system at the proper pressure and for the correct duration.
5. Properly document the test results on the appropriate form.

The employee is: **qualified** **not qualified to perform Task 6.**

Task 7. Regulator Selection

Use Figure X and the regulator manufacturer's charts, determine the correct regulator for the system.

1. Determine the type of regulator or regulators needed for each section of piping on the system.
2. Determine the total BTU requirements of the appliances served by each section of piping.
3. Determine the minimum and maximum BTU requirements of all the appliances served by that section of piping.
4. Select a regulator from the manufacturer's catalog that will supply LPG at the correct pressure and flow rate.

The employee is: **qualified** **not qualified to perform Task 7.**

Task 8. Regulator Inspection

At a residential installation, inspect the system regulator or regulators for proper installation and protective measures.

1. Verify that the regulator vents are protected by one or more of the following means:
 - Installation with the vent pointing down
 - Installation under a protective dome
 - Installation in or under a protective cover
 - Installation of a vent pipe-away adapter
 - Installation of an insect screen at the vent discharge
2. Verify that the regulator adjustment cap is in place and secured.
3. Verify by visual inspection that the regulators are the correct type, had no apparent defect, and met company standard operating procedures and/or policies for regulator inspection.

The employee is: **qualified** **not qualified to perform Task 8.**

Task 9. Field Leak Check

At a residential installation, perform a leak check according to NFPA requirements.

1. Install the appropriate test fitting in the test tap of the second-stage regulator and connect a manometer or other suitable pressure measuring device.
2. Verified that all appliances are connected, that appliances with 100 percent safety valves are in the on position, and any appliances with standing pilots are turned off.
3. Pressurize the system to normal working pressure; then reduce pressure to 9 inches w.c. \pm 1/2 inch for three minutes.
4. Document test results on the appropriate form.

The employee is: qualified not qualified to perform Task 9.

Task 10. System Purging

At a residential installation following a system leak check, purge the distribution piping system of air and place the appliances into service according to the manufacturers' instructions.

1. After checking each gas appliance for proper venting and ventilation and ensuring that the controls are in the off position, find a suitable location for purging the piping system (at the farthest appliance from the supply container, if appropriate).
2. Using methods to control ignition sources, such as a combustible gas indicator (CGI), purge air and gas/air mixtures from the piping until the gas/air mixture approaches but is less than the lower flammability limit; stop purging and seal the piping opening.
3. After allowing time for proper ventilation, place each gas appliance into operation according to the manufacturer's instructions.
4. Cycle each appliance through three main burner cycles to verify proper burner operation.

The employee is: qualified not qualified to perform Task 10.

Task 11. Regulator Flow Pressure Test

At a residential installation, perform a regulator flow pressure test and adjust the pressure setting if appropriate.

1. Install the appropriate test fitting in the test tap of the second-stage regulator or an appliance shutoff.
2. Connect a manometer or other suitable pressure-measuring device and check the connections for leakage.
3. Operate a gas appliance to verify that gas is flowing; then check the pressure reading to assure that the regulator was set for the proper delivery pressure.
4. Operate the remaining appliances to verify that flow pressure does not fall below the minimum input pressure specified by the appliance manufacturers. If the flow pressure is inadequate, identify correction measures.

Record the results of the flow pressure test on the appropriate company form.

6. Disconnect the testing equipment and verify that no gas is leaking using a suitable gas leak detection solution or device.

The employee is: **qualified** **not qualified to perform Task 11.**

Task 12. Regulator Lock-Up Test

At a residential installation, perform a regulator lock-up test.

1. Install the appropriate test fitting in the test tap of the second-stage regulator or an appliance shutoff.
2. Connect a manometer or other suitable pressure-measuring device and check the connections for leakage.
3. Record the regulator flow pressure on the appropriate company form; then close each appliance shutoff.
4. Observe the pressure-measuring device for a rise in pressure and record the observed lock-up pressure.
5. Continue to observe the pressure-measuring device for at least one minute to ensure that the pressure did not continue to creep up.
6. If the lock-up pressure exceeded flow pressure by more than 30 percent, or if the regulator failed to lock up, the student replaced the regulator with a suitable replacement.

The employee is: **qualified** **not qualified to perform Task 12.**

Task 13. Consumer Safety Communications

Use company-prescribed consumer safety information and product warning materials to demonstrate or explain primary consumer safety messages and product warnings.

1. Show the customer how to turn off the gas at the container service valve or valves in the event of a gas leak of other safety-critical situation.
2. Vent a small amount of propane from the container's fixed maximum liquid level gauge, have the customer say if he or she could detect the smell of propane odorant, and ask the customer to describe the smell.
3. Point out the container's pressure relief valve and instruct the customer to be sure that no one is allowed to place any body part directly over or in line with the relief valve discharge, and to call the company if the relief valve vents propane vapor.
4. Instruct the customer that the tank dome should be closed (but never locked) at all times, except when the company is servicing the tank.
5. Inside the house, locate and point out the location of each gas appliance shutoff valve, and explain to the customer the importance of shutting off the gas at appliances in the event of a gas leak or interruption of gas service.
6. Explain to the customer that propane vapor is heavier than air and may collect near the floor or underground and in low areas in the event of a leak.
7. Explain to the customer that propane leak detectors and carbon monoxide detectors with alarms designed for consumers are available at hardware stores and home improvement centers, and their use is recommended. Also explain that detectors should be installed according to their manufacturers' instructions.
8. Point out the company's emergency phone number and instruct the customer to call if unusual odors are smelled, an appliance malfunctions, or other safety-critical situations are detected.
9. Document the delivery of these safety messages, product warnings, and the company's consumer information to the customer, and have the customer acknowledge receipt with his or her signature and the date.

The employee is: **qualified** **not qualified to perform Task 13.**

IV. EMPLOYER RECORD OF ADVANCED FIELD TRAINING ACTIVITIES

Employee Information (print or type)

Employee Name _____

Employer Name _____

Address _____

City, State, ZIP _____ Date _____

Company Representative (print or type)

Name _____

Organization or Employer _____

Telephone _____

Signature _____ Date _____